

# KALFLEX® Flexible Wear Protection

**Effective Wear Protection in Pipes and Elbows  
Adapts to Movement Quickly and Easily**



KALFLEX® wear resistant flexible pipe systems provide a cost-effective solution for connecting conveying system components that move due to vibration, thermal expansion, or as a result of intended movement. The flexible system can be easily integrated into existing pipe systems using normal flanging and works well in pneumatic conveying equipment. The elbows are useful in replacing worn components of undetermined angle or radius.

The interior of flexible KALFLEX is composed of individual wear resistant segments to provide flexibility. The segments are enclosed in an engineered rubber jacket to ensure stability and tightness.

Depending on the application, KALFLEX piping components can be supplied with KALCAST® hard cast iron or KALOCER high alumina ceramic.

- Quick, easy, cost-effective installation.
- Uses a variety of flange and coupling connections.
- Flexible radius and angle positions.
- Temperature range up to 110°C/230°F down to -30°C/-22°F.
- Maximum 10 bar pressure (145 psi).
- Sizes range from 19 to 200 mm (0.75" to 7.87") ID.
- Absorbs vibration and thermal expansion.
- Isolates weighing equipment.
- Highly wear resistant.
- UV ozone and weather resistant.
- Useful in diverter valves or as an expansion joint.

**KALFLEX**  
Flexible wear protection

# KALFLEX® Flexible Wear Protection

## KALFLEX Components Lined with KALCAST® or KALOCER Protect Pipe and Bends From Extreme Wear

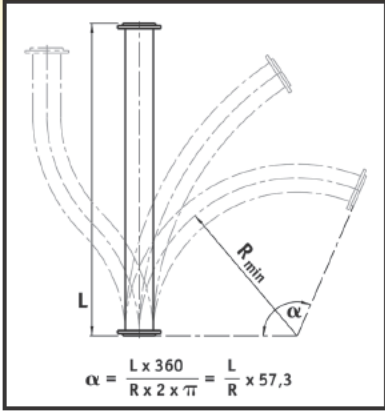

### KALCAST® For Impact Wear and Sliding Abrasion

KALCAST hard cast iron segments are used in KALFLEX components to withstand wear from impact and sliding abrasion. Select from a variety of alloying compounds with hardness from 580-700 HV, to optimize protection in specific applications. Diameters range from 19 mm to 200 mm (.75" to 7.87") ID.

### KALOCER For Use in Extreme Wear

KALOCER alumina oxide ceramic segments with a Moh's hardness of 9, are used in KALFLEX components exposed to extreme abrasive wear. When KALOCER is used, the end segments are made of KALCAST and the flanges are carbon steel for strength. Diameters range from 50 mm to 125 mm (1.97" to 4.92") ID.

KALFLEX Dimensions for KALCAST® Cast Iron											
Dimensions								Weight			
Pipe ID		Length				Radius minimum		L min.		L max.	
		L min.	L max.								
mm	inches	mm	inches	mm	inches	mm	inches	kg	lbs	kg	lbs
19	0.75	210	8.27	1510	59.45	250	9.84	4.7	10.3	12.5	27.5
24	0.94	210	8.27	1510	59.45	250	9.84	5.9	13	15.8	34.8
32	1.26	288	11.34	1548	60.94	300	11.81	7.5	16.5	20.1	44.2
40	1.57	285	11.22	1558	61.34	350	13.78	10.3	22.7	31.2	68.6
50	1.97	284	11.18	2070	81.50	459	18.07	13.6	29.9	44	96.8
65	2.56	345	13.58	2055	80.91	600	23.62	17.1	37.6	54.9	120.8
80	3.15	345	13.58	2530	99.61	800	31.50	19.9	43.8	79.7	175.3
100	3.94	365	14.37	2550	100.39	1000	39.37	26.5	58.3	102.4	225.3
125	4.92	410	16.14	2590	101.97	1200	47.24	34.7	76.3	128.2	282
150	5.91	410	16.14	2542	100.08	1400	55.12	48.5	106.7	153	336.6
175	6.89	430	16.93	2110	83.07	1400	55.12	53.5	118	157.5	347
200	7.87	430	16.93	2155	84.84	1400	55.12	59.0	130	171.5	377

For dimensions and weights for KALOCER, contact Kalenborn Abresist.

**Kalenborn Abresist offers pre-engineered linings matched to each application. Our services include:**

- Engineering
- Installation on-site
- Complete steel fabrications
- Supervision of customer or contractor labor

**Experience with:**

- Bottom and fly ash
- Ore
- Coal/coke
- Iron oxide
- Dried sewage fertilizer
- Cement/clinker
- Grain
- Carbon
- Limestone
- Sand
- Glass/cullet
- Hog fuel/woodchips



### Kalenborn Abresist Corporation

5541 North State Road 13, Urbana, IN 46990  
 Phone: 260-774-3327 • Toll Free: 800-348-0717  
[www.kalenborn.us](http://www.kalenborn.us) • E-mail: [info@abresist.com](mailto:info@abresist.com)