

»» **Optimal Wear Protection and  
Reliable Slide Promotion**

**for Plant Components  
and Pipes**



# >> The Lining People

**Comprehensive Range of Wear Protection and Slide Promotion Systems – Worldwide**

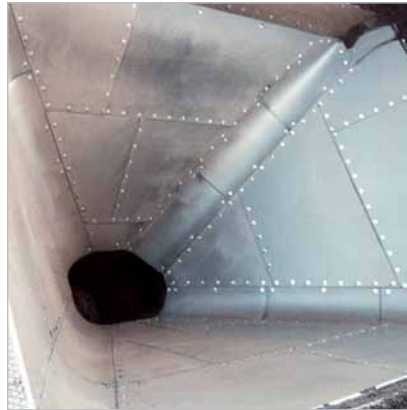

**Cost of spare parts, repairs and operational failures can be avoided**

Kalenborn is one of the leading companies worldwide for wear protection solutions in basic industry. Mineral and ceramic materials are used to protect against extremely high sliding friction wear. Metallic materials are particularly suited whenever there is a combination of sliding, friction and impact. Other materials made of rubber and plastic have performed well, especially for impact angles of approximately 90 degrees.

**Kalenborn always offers the best possible solution for problems of wear**

**Correct linings provide uninterrupted production and avoid plant shutdowns**

Conveying systems frequently suffer flow problems. These deficiencies can be significantly reduced by selective measures for lowering wall friction and preventing adhesion, i.e. by the installation of slide-promoting materials.

A variety of materials and linings using appropriate fixing alternatives are offered for these tasks.

**Kalenborn offers reliable solutions for many flow problems**

**Available all over the world and 24 hours online: [www.kalenborn.com](http://www.kalenborn.com)**

The Kalenborn Group is active all over the world. It offers solutions with optimal wear protection and reliable slide promotion of plant components and pipes on the basis of experience gathered over the past 80 years. The Kalenborn head office is in Germany, with affiliated companies and subsidiaries in USA, Canada, Brazil, France, Poland, Hungary, Singapore and Philippines. A network of more than 25 agencies in countries all over the world ensures good contact with its business partners.

The internet provides access to all current literature and technical information and enables contact with Kalenborn any time.

**For its customers Kalenborn is always within reach**

# >> Comprehensive Offers including Design, Manufacture, Delivery and Installation

Kalenborn has been dedicated to plant protection since developing fused cast basalt for wear reduction and cost savings.

Starting with fused cast basalt more than 90 years ago, Kalenborn has developed a wide range of wear resistant materials with each material offering special wear resistant characteristics.

The materials are valuable, but the knowledge from the experience gathered all over the world in more than eighty branches of industry is just as important.

## Design

Our engineers design customized cost saving solutions for new or existing equipment.

All the details of the solution come from a single source: starting with advice on application, measurements on-site, design services, manufacture of the lining through to proper installation. This is the background of solutions that offer long lasting protection.



## Manufacturing

The foundation of the abrasion resistant systems offered by Kalenborn consists of different mineral, ceramic and metallic materials as well as rubber and plastic with a wide range of individual characteristics.

## Installation and Erection

Proper installation and erection require knowledge based on a wide range of experience. Installation of the engineered wear resistant linings can be performed or supervised by Kalenborn specialists in our workshops or on-site all over the world.

## Which material for which task?

Wear protection should be matched to each application. The better the match between the lining material and the specific problem the more durable and economical the solution.

The most suitable material is determined after all influencing factors are known. There is no magic formula or specific calculation principle: the decision is based on knowledge of more than 90 years of practical experience of Kalenborn.





# >> Wear Protection

## ABRESIST

Fused Cast Basalt



Wear resistant fused cast basalt for friction induced abrasion

Mineral basalt-based wear protection for plant components when the conveying material produces friction induced abrasion.

### Installation

Pipes or shaped components in cement mortar or other setting materials. Mechanical fixings are feasible as well.

### Application temperature

Up to approximately 350 °C/ 662 °F depending on application and geometry.

### Advantages

Highly abrasion resistant, smooth surface that lasts, no corrosion.

## KALCOR

Zirconium Corundum



Wear protection characterized by high temperature and abrasion resistance

Cast material of alumina and zirconia for plant components, where extreme wear and high temperature occur.

### Installation

Pipes or shaped components in cement mortar or special setting materials. Mechanical fixings are feasible as well for heavy vibrations and high temperature.

### Application temperature

Up to approximately 1000 °C/ 1832 °F, depending on application and geometry.

### Advantages

Highly abrasion resistant, temperature resistant, corrosion resistant.

## KALOCER

High Alumina Ceramics

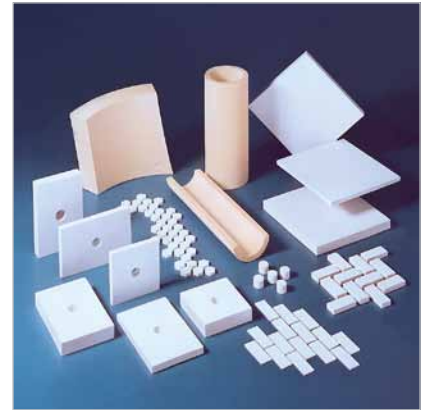

Material characterized by high wear and temperature resistance

Special alumina ceramics for plant components with extreme wear and/or temperature conditions, for thin linings or for smooth surfaces.

### Installation

Shaped components or thin tiles laid in KALFIX synthetic mortar. Vulcanized in rubber as KERAFLEX for installation by gluing or with mechanical fixing.

### Application temperature

Up to 1000 °C/1832 °F, depending on application and geometry.

### Advantages

Highly wear resistant, smooth surface that lasts, no corrosion, available from 1.5 mm thickness.

## KALSICA

Silicon Carbide Ceramics



Ceramic material highlighted by excellent abrasion resistance at high temperature

Silicon carbide ceramics for plant components for extreme wear, high temperature and/or thermal shock:

- KALSICA-S silicon infiltrated
- KALSICA-N and KALSICA-P nitride bonded
- KALSICA-M metal bonded

### Installation

In synthetic resin or mineral based adhesives or in heat and acid resistant cements. Mechanical fixings are feasible as well.

### Application temperature

Up to approximately 1000 °C/ 1832 °F depending on application and geometry.

### Advantages

Highly to extremely abrasion resistant, very resistant to thermal shocks and manufactured to small tolerances.

## KALMETALL-W

Hard Overlay Welding



Advantageous in cases of impact stress and for large surfaces

Different hard faced steel systems are offered under the designation KALMETALL-W. They consist of a strong base material and the hardfacing.

### Installation

If required, self-supporting combinations are feasible.

### Application temperature

Up to approximately 750 °C/ 1382 °F depending on the material chosen with respect to base material and hardfacing.

### Advantages

Depending on the alloy chosen characterized by high abrasion resistance, high impact and/or temperature resistance, low weight and high economy of self-supporting structures.

## KALMETALL-C

Hard Cast Alloy



Different alloys featuring either extreme hardness or impact resistance

KALMETALL-C may either be extremely resistant to abrasive wear or impact wear.

### Installation

Custom-made shaped components to be fixed mechanically or laid in mortar or adhesives.

### Application temperature

Up to 350 °C/ 662 °F depending on application and geometry.

### Advantages

Optimally balanced wearprotection material that offers also high resistance to impact wear, cost-effective for series-produced components.

# >> Wear Protection

**KALCRET**  
Hard Compound



Cast or trowelled materials for continuous linings

KALCRET hard compound is the general term for cement-bonded wear protection materials. The wear resistance is governed by the hard compound chosen for the particular application. KALCRET enables continuous lining of plant components where high wear and temperature occur.

## Installation

By trowelling or casting in formwork, prefabricated shaped components and pipes.

## Application temperature

Up to approximately 1,200 °C/  
2192 °F depending on application and geometry.

## Advantages

Highly resistant to abrasion and compressive stress, continuous lining, resistant to high temperatures. Even components of complicated geometry can be protected by KALCRET.

**Combined Linings**  
more Economical

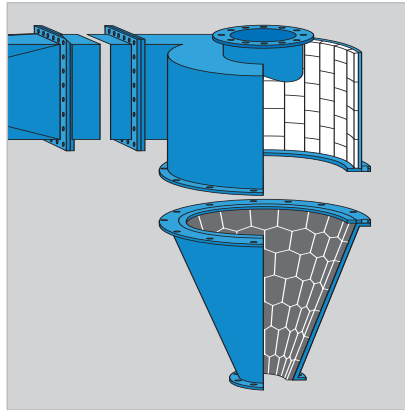

Identical lifetimes for all plant components

The intensity of wear often varies for the different system sections. Moreover, stress varies repeatedly either due to sliding abrasion, impact wear, temperature or temperature changes.

This is where a combination of the different wear resistant linings proves successful. Designed on the basis of prior successful experience, components can achieve similar lifetimes without premature failure or excessive protection.

**Systems**  
for Wear Protection

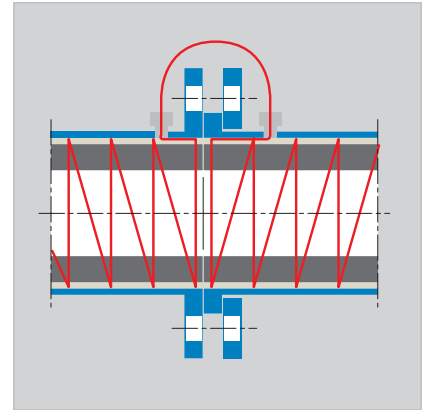

Optimized solutions for specific applications

Kalenborn has developed a program of wear protection systems that allow handling of special problems of wear. These include:

### ■ KALDETECT wear monitoring system

Electrical, pneumatic or mechanical devices that indicate possible wear of the lining.

### ■ KERAFLEX ceramics rubber bonding

Vulcanized bonding of KALOCER, rubber and steel, combining hard ceramics with impact resistant rubber.

### ■ Kalenborn deviation pots

Deviation pots for pneumatic transport pipes lined with an optimal material and requiring little space.

# >> Slide Promotion

## KALEN

Slide Promotion Plastics

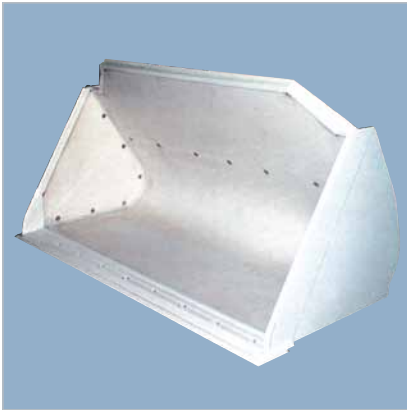

**Synthetic materials characterized by particularly good slide promotion properties**

KALEN materials are highlighted by good corrosion resistance, an excellent surface finish and low weight:

- KALEN-PE polyethylene
- KALEN-PP polypropylene
- KALEN-PVC polyvinyl chloride

### Installation

Mechanical fixing by means of different types of screwed connections, doweling methods and specific weld studs with special nuts.

### Application temperature

Up to 100 °C/ 212 °F depending on the material concerned.

### Advantages

Very good slide promotion combined with extremely good corrosion resistance, excellent surface finish and low weight.

## KALINOX

Slide Promotion Steel



**Slide promotion and abrasion protection**

Depending on the requirements, KALINOX is delivered either as sheets made from different types of high-grade stainless steel or as an integral lining, part of the sub-structure.

### Installation

In steel structures the sheet segments are welded to each other; in case of concrete the elements are doweled to the concrete surface.

### Application temperature

Up to approximately 350 °C/ 662 °F depending on application and geometry.

### Advantages

Good slide promotion combined with good wear protection properties. KALINOX is useful whenever plastic linings lack the required wear resistance.

## KALCERAM

Hard Ceramics

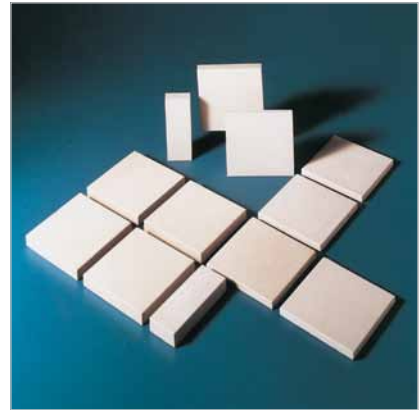

**Abrasion resistant hard ceramics featuring good sliding properties**

KALCERAM is particularly suitable where in addition to sticking problems intense wear occurs and the wear resistance of higher quality linings cannot be economically justified.

### Installation

Tiles cut to the specific dimensions are laid either in cement mortar or KALFIX synthetic mortar.

### Application temperature

Up to approximately 350 °C/ 662 °F depending on application and geometry.

### Advantages

Smooth surface to ensure good sliding properties and hard ceramics with average wear resistance.

# >> Optimal Solutions for Problems of Wear and Flow

The lining of pipes, pipe bends as well as production and conveying systems by mineral, ceramic and metallic materials as well as rubber and synthetic materials has proven successful in actual practice. Material combinations that allow system optimization have turned out to be of particular advantage.

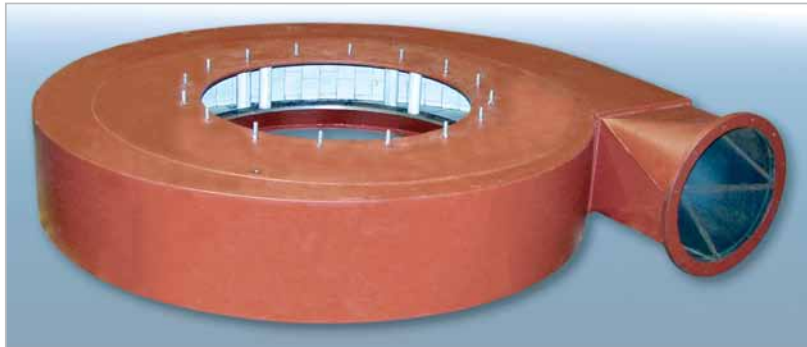

## Typical example:

**Extremely hard KALOCER high alumina ceramics to withstand maximum wear, KALMETALL-W hard overlay welding as self-supporting structure in case of moderate wear and for lowering the overall weight. All this in one plant component: an optimal solution.**



Ask Kalenborn Abresist for further information

**Kalenborn Abresist**  
PO Box 38, 5541 North State Road 13  
Urbana, IN 46990

Phone (800) 348-0717  
Sales Fax (260) 774-3832  
email: [info@abresist.com](mailto:info@abresist.com)  
[www.kalenborn.us](http://www.kalenborn.us)

 **Kalenborn**  
Wear Protection Solutions

ABRESIST, KALCERAM, KALCOR, KALCRET, KALEN, KALENBORN, KALFIX, KALINOX, KALMETALL, KALOCER, KALPOXY, KALPROTECT, KALRESIST and KALSICA are trademarks of Kalenborn Kalprotect.

This brochure and other technical information are general only. They do not cover any guarantee with legal effect. Technical changes and errors are reserved.